

# Adept Cobra s600



## Specifications

Reach	600 mm
Payload	
Rated	2 kg
Max.	5.5 kg
Adept Cycle	
Burst Mode	0.42 sec
Sustained (20°C)	0.45 sec
Joint Ranges	
Joint 1	± 105°
Joint 2	± 150°
Joint 3	210 mm
Joint 4	± 360°
Joint Speeds	
Joint 1	386°/sec
Joint 2	720°/sec
Joint 3	1100 mm/sec
Joint 4	1200°/sec
Repeatability	
XY	± 0.017 mm
Z	± 0.003 mm
Theta	± 0.019°
Pass-Through Connections	
Electrical	24 (12 twisted pairs)
Pneumatic	6 mm (x2) 4 mm (x3)
DeviceNet	1
Digital I/O Channels	
AIB:	12 inputs, 8 outputs
Controller:	12 inputs, 8 outputs
Optional solenoid:	4 outputs
Weight	41 kg
Environmental Requirements	
Ambient Temperature	5 - 40 °C
Humidity Range	5 - 90 % (non-condensing)
Power Requirements for SmartController	
24 VDC : 5 A	
Power Requirements for AIB	
24 VDC : 6 A	
200 - 240 VAC : 10 A, single-phase	
CE and cULus Compliant	

The Adept Cobra™ s600 robot is a high-performance SCARA robot system for mechanical assembly, material handling, packaging, machine tending, screw driving, and other applications that require fast and precise automation. Adept Cobra s-Series robots include the Adept SmartController™ motion controller, which provides performance capabilities unmatched in the industry.

## Product Features and Benefits

- Adept ACE™ software to deploy your applications through a user-friendly interface
- High-resolution, absolute encoders to provide high accuracy, superior slow-speed following, and easy calibration
- High-efficiency, low-inertia Harmonic Drives™ and a lightweight arm to deliver maximum acceleration
- 8 kHz™ servo update rate to improve path following and control
- Diagnostics display enables faster troubleshooting
- Ethernet TCP/IP capability to control the robot through a PC, PLC, or controller
- Complete interchangeability between robots and controllers



The Adept Cobra s600 robot comes with the high-performance Adept SmartController motion controller, which is based on the Adept SmartServo architecture. It has a small footprint of 329w x 187d x 86h mm.

# Adept Cobra s600

## Dimensions: Adept Cobra s600 (mm)

Work Envelope: Radius 600 mm  
Inner Limit: Radius 163 mm  
Height: 210 mm

Required clearance to open AIB Chassis

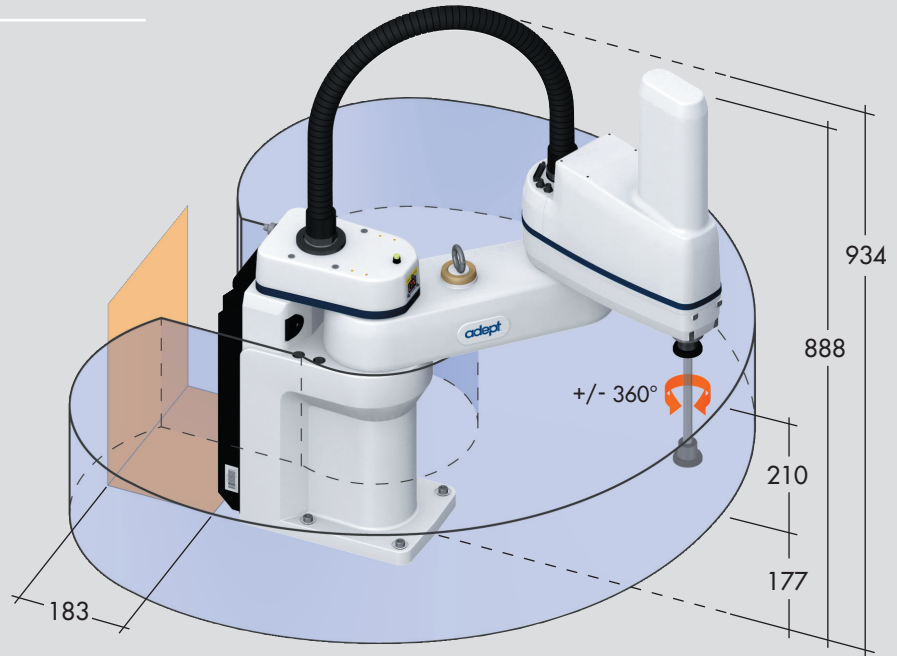

## Dimensions: Flange (mm)

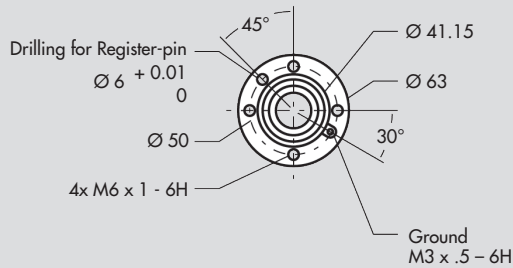

## Dimensions: Footprint (mm)

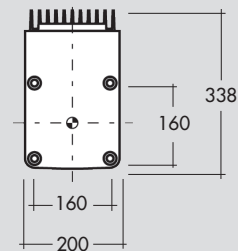

## The Adept Cobra s600 system includes the following:

- Adept Cobra s600 robot with AIB (Amplifiers In Base)
- Adept SmartController motion controller
- Front panel with E-Stop
- Adept ACE software
- User documentation

## Options and Peripherals:

- AdeptSight™ vision guidance and inspection system (requires a PC—Adept recommends using the Adept SmartVision™ EX)
- T2 manual control pendant
- Dual robot configuration option
- Conveyor-tracking option
- sMI6 SmartMotion™ interface
- sDIO I/O expansion (32 digital input and 32 digital output channels)
- IO Blox I/O module (8 digital input and output channels each)
- High-resolution Joint 4 option
- Solenoid valve kit
- Cleanroom ISO4 (class 10) option/ ESD option
- Adjustable Hardstop Kit

## Downloads:

- Download CAD files for the Adept Cobra s600 robot from <http://www.adept.com/support/downloads/file-search> using the following download ID: 500007



Adept Technology, Inc. 5960 Inglewood Drive, Pleasanton, CA 94588

Tel: 925-245-3400 Fax: 925-960-0452 Email: [info@adept.com](mailto:info@adept.com)

[www.adept.com](http://www.adept.com)

Specifications subject to change without notice.

©2011 Adept Technology, Inc. ALL RIGHTS RESERVED. The information provided in this communication or document is the property of Adept Technology, Inc. and is protected by copyright and other intellectual property laws. In addition, any references to any Adept Technology, Inc. products are the marks and property of Adept Technology, Inc. [and may be registered trademarks]. All other trademarks or tradenames are the property of their respective holders.